

Tous droits strictement réservés. Reproduction ou communication a des tiers interdite sous quelque forme que ce soit sans autorisation écrite du propriétaire. Propriété de c FCI. Droits de reproduction FCI.

FCI

All rights strictly reserved. Reproduction or issue to third parties in any form whatever is not permitted without written authority from the proprietor. Property of FCI. Copyright FCI.

PRODUCT NO.	ROWS	POWER					SIGNAL					POWER										E1								
		E2	P21	P20	P19	P18	P17	6	5	4	3	2	1	P16	P15	P14	P13	P12	P11	P10	P9		P8	P7	P6	P5	P4	P3	P2	P1
51897-003-- NOTE: 3	D C B A		PH	PH	PF	PF	PC	F	F	F	F	F	F	F	F	F	F	F	F	F	F	F	F	F	F	F	F	F	F	

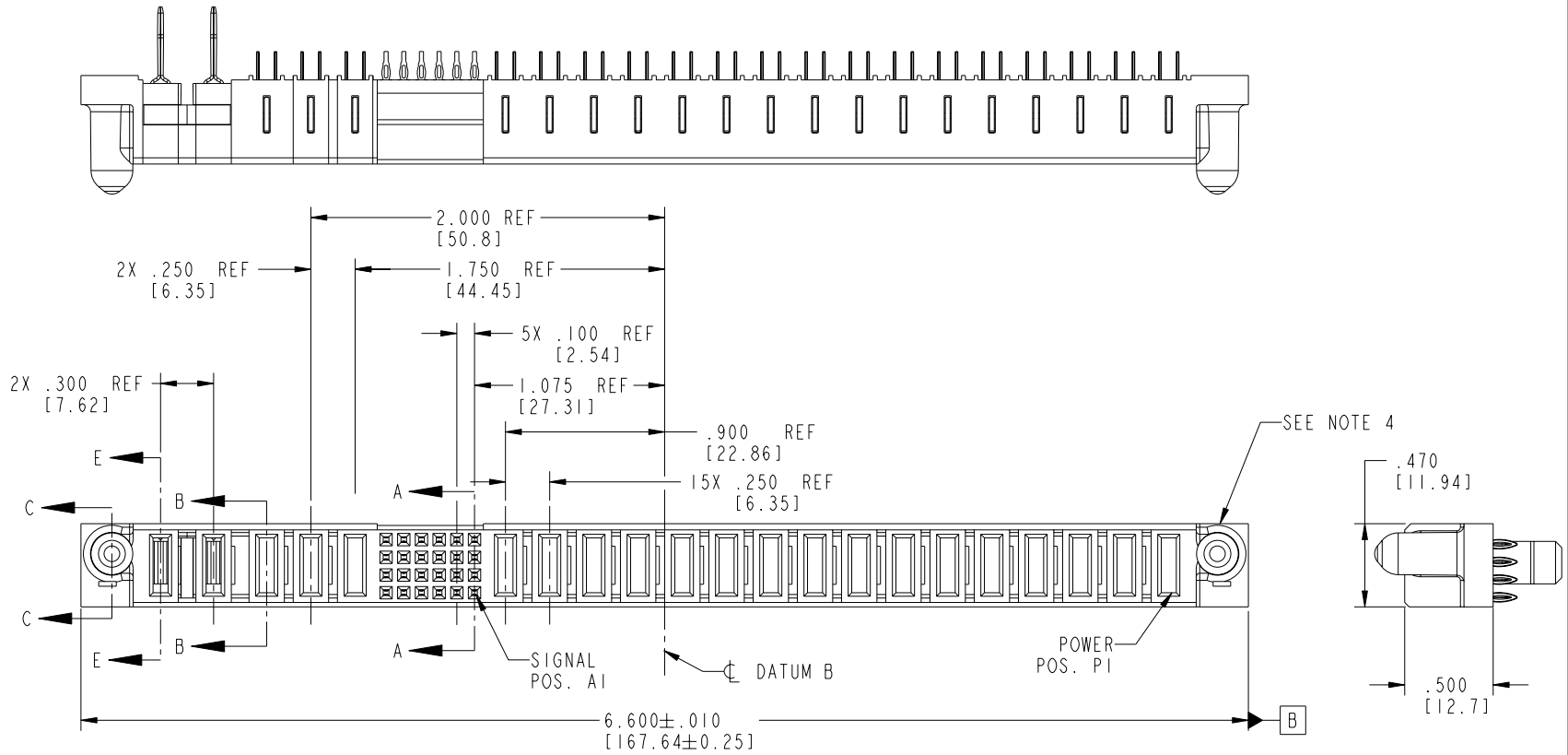

CODE	DIM "M" MATING LENGTH	CONTACT TYPE
F	N/A [N/A]	SIGNAL
PC	.042 [1.07]	POWER
PF	.092 [2.34]	POWER
PH	.092 [2.34]	POWER

mat'l code				SEE NOTE 2		tolerances unless otherwise specified		CUSTOMER		FCI www.fciconnect.com		
ltr	ecn no.	dr	date	linear	.XX ± .01/0.X ± 0.3		COPY		title 6P + 24S + 2P + 3ACP			
A	V03-0795	TAB	07/17/03		.XXX ± .005/0.XX ± 0.13		projection		VERTICAL PRESS-FIT RECEPT			
B	DG05-0240	GuoJM	07/26/05	angles	.XXX ± .0020/0.XXX ± 0.051		INCH/MM		product family			
				dr	T.BRUNGARD	12/09/02	scale		PwrBlade		code	
				enr	M. MOSTOLLER	12/09/02	1:1		size		213	
				chr	M. MOSTOLLER	12/09/02			dwg no		sheet	
				appd	M. MOSTOLLER	12/09/02			A		51897-003	1 of 4
sheet index		revision sheet		B	B	B	B					
				1	2	3	4					

1 | 2

Pro/E

3 |

cage code 22526

4

PDM: Rev:B

STATUS: Released

Printed: Aug 15, 2007

Tous droits strictement réservés. Reproduction ou communication a des tiers interdite sous quelque forme que ce soit sans autorisation écrite du propriétaire. Propriété de c FCI. Droits de reproduction FCI.

A FCI

All rights strictly reserved. Reproduction or issue to third parties in any form whatever is not permitted without written authority from the proprietor. Property of FCI. Copyright FCI.

PRODUCT NUMBER
51897-003__
NOTE: 3

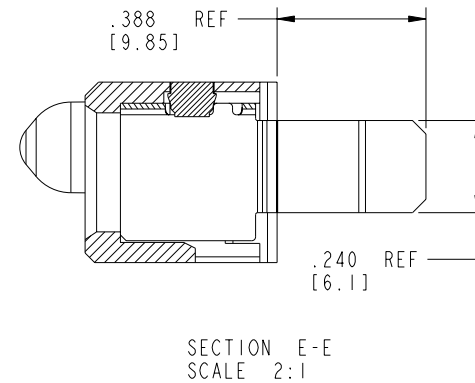
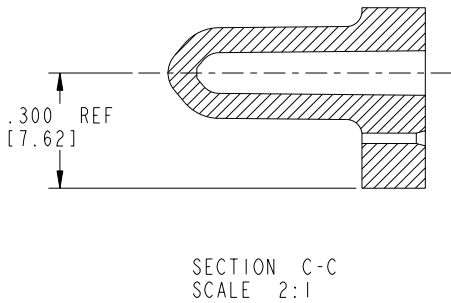
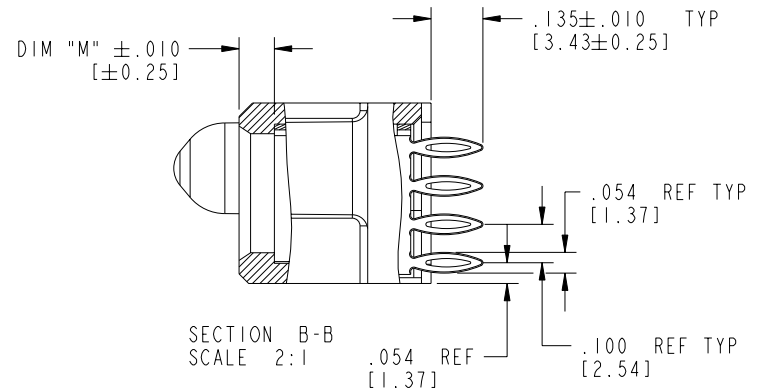
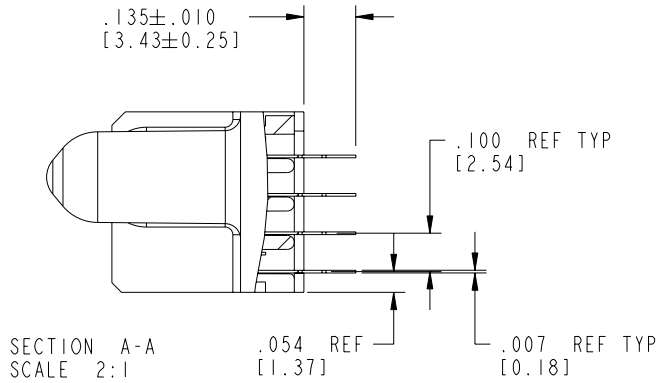

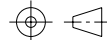
mat'l code				SEE NOTE 2		tolerances unless otherwise specified		CUSTOMER		 www.fciconnect.com	
ltr	ecn no.	dr	date	linear	.XX±.01/0.X±0.3		COPY		title 6P + 24S + 2P + 3ACP		
B					.XXX±.005/0.XXX±0.13		projection		VERTICAL PRESS-FIT RECEPT		
					.XXX±.0020/0.XXX±0.051				product family		code
					° ± °		INCH/MM		PwrBlade		213
				dr	T. BRUNGARD	12/09/02	scale		size		sheet
				enr	M. MOSTOLLER	12/09/02	1:1		A		2 of 4
				chr	M. MOSTOLLER	12/09/02			51897-003		
				appd	M. MOSTOLLER	12/09/02					
sheet index	revision sheet								cage code	22526	

Pro/E

cage code 22526

PDM: Rev:B

STATUS: Released

Printed: Aug 15, 2007

Tous droits strictement réservés. Reproduction ou communication à des tiers interdite sous quelque forme que ce soit sans autorisation écrite du propriétaire. Propriété de c FCI. Droits de reproduction FCI.

FCI

All rights strictly reserved. Reproduction or issue to third parties in any form whatever is not permitted without written authority from the proprietor. Property of FCI. Copyright FCI.

PRODUCT NUMBER
51897-003__
NOTE: 3

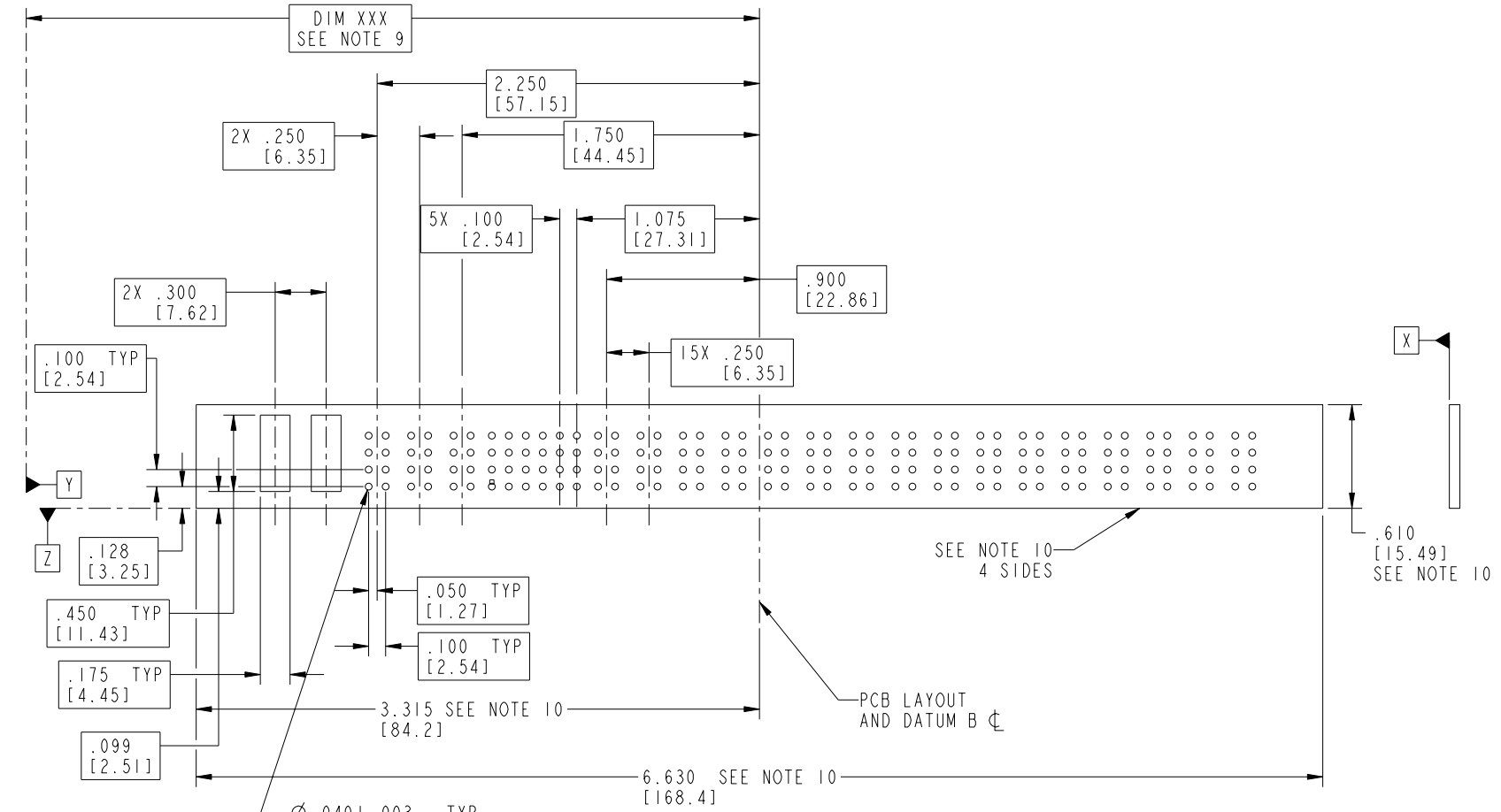

Ø.040±.003 TYP
[1.02±0.07]
SEE NOTE 8
⊕ Ø.004 [0.1] X Y Z

mat'l code				SEE NOTE 2		tolerances unless otherwise specified		CUSTOMER		FCI www.fciconnect.com	
ltr	ecr no.	dr	date	linear	.XX±.01/0.X±0.3		COPY		title 6P + 24S + 2P + 3ACP VERTICAL PRESS-FIT RECEPT		
B					.XXX±.005/0.XXX±0.13		projection				
					angles	.XXX±.0020/0.XXX±0.051		INCH/MM		product family PwrBlade code 213	
				dr		T.BRUNGARD	12/09/02	scale 1:1		size dwg no 51897-003 sheet 3 of 4	
				enr	M. MOSTOLLER	12/09/02					
				chr	M. MOSTOLLER	12/09/02					
				appd	M. MOSTOLLER	12/09/02					
sheet index	revision sheet										

cage code 22526

Pro/E

Tous droits strictement réservés. Reproduction ou communication a des tiers interdite sous quelque forme que ce soit sans autorisation écrite du propriétaire. Propriété de c FCI. Droits de reproduction FCI.

A FCI

All rights strictly reserved. Reproduction or issue to third parties in any form, whenever is not permitted without written authority from the proprietor. Property of FCI. Copyright FCI.

A

B

PRODUCT NUMBER
51897-003__
NOTE: 3

NOTES:

1. DIMENSIONS AND TOLERANCES ARE IN ACCORDANCE WITH ASME Y14.5M, 1994 UNLESS OTHERWISE SPECIFIED.

CONNECTOR NOTES:

2 HOUSING MATERIAL: UL 94 V-0 GLASS FILLED

HIGH-TEMP THERMOPLASTIC
POWER CONTACT MATERIAL: COPPER ALLOY
SIGNAL PIN MATERIAL: COPPER ALLOY

3. PLATING:

51897-003 Singal Pin:30u"/0.76um Au OVER 50u"/1.27um Ni ON THE CONTACT AREA,
AND 100u"/2.54um SnPb PLATING OVER 50u"/1.27um Ni ON THE TERMINATION SECTION.
Power Pin:30u"/0.76um Au OVER 50u"/1.27um Ni ON THE CONTACT AREA,
AND 100u"/2.54um SnPb PLATING OVER 50u"/1.27um Ni ON THE TERMINATION SECTION.

51897-003LF Singal Pin:30u"/0.76um Au OVER 50u"/1.27um Ni ON THE CONTACT AREA,
AND 78u"/2.00um Sn PLATING OVER 50u"/1.27um Ni ON THE TERMINATION SECTION.
Power Pin:30u"/0.76um Au OVER 50u"/1.27um Ni ON THE CONTACT AREA,
AND 78u"/2.00um Sn PLATING OVER 50u"/1.27um Ni ON THE TERMINATION SECTION.

PART NUMBER 51897-003LF MEETS EUROPEAN UNION DIRECTIVE AND OTHER COUNTRY REGULATIONS AS DESCRIBED IN GS-22-008.

THE HOUSING WILL WITHSTAND EXPOSURE TO 260° PEAK TEMPERATURE FOR 10 SECONDS IN A WAVE SOLDER APPLICATION WITH A CIRCUIT BOARD.
(AND SnPb ON PCB INTERFACE)

4 MANUFACTURER'S NAME, P/N, AND DATE CODE TO APPEAR ON THIS SURFACE.

5. PRODUCT SPECIFICATION GS-12-149.
APPLICATION SPECIFICATION BUS-20-067.

PCB NOTES:



6. ALL HOLE DIAMETERS ARE FINISHED HOLE SIZE.

7. MOUNTING HOLES, WHERE APPLICABLE, ARE UNPLATED.

8 $\varnothing .0453 \pm .0010$ [1.151 \pm 0.025] DRILLED HOLES PLATED WITH
.0003 [0.008] MIN SnPb OVER .001 [0.03]
TO .003 [0.08] Cu PLATING TO ACHIEVE
 $\varnothing .040 \pm .003$ [1.02 \pm .07] HOLE.

9 "DIM XXX" TO BE DETERMINED BY THE CUSTOMER.

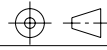
10 CONNECTOR KEEP-OUT ZONE.

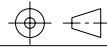
mat'l code				SEE NOTE 2		tolerances unless otherwise specified		CUSTOMER		 www.fciconnect.com	
ltr	ecn no.	dr	date	linear	.XX \pm .01/0.X \pm 0.3		COPY		 title 6P + 24S + 2P + 3ACP VERTICAL PRESS-FIT RECEPT		
B					.XXX \pm .005/0.XX \pm 0.13		projection				
				angles	.XXX \pm .0020/0.XXX \pm 0.051		 INCH/MM		product family PwrBlade code 213 size dwg no 51897-003 sheet 4 of 4		
					0 \pm 2°		scale 1:1				
				dr	T.BRUNGARD	12/09/02	 INCH/MM scale 1:1		product family PwrBlade code 213 size dwg no 51897-003 sheet 4 of 4		
				enr	M. MOSTOLLER	12/09/02					
				chr	M. MOSTOLLER	12/09/02					
				appd	M. MOSTOLLER	12/09/02					
sheet index	revision sheet										

A

B

1 | 2

3 |

4

1 | 2

Pro/E

3 |

cage code 22526

4